



# Quick Installation Guide

## **Q-CONNECTOR V2** *Hydraulic Quick Coupler*

Pre-Pressed Version



## Preparation Checklist

Please gather the following tools to ensure a smooth installation:



- Brake Bleed Kit  
(Must be compatible with your brake brand)



- Hydraulic Hose Cutter  
(Essential for a clean, flat cut)



- Standard Wrench



- Cleaning Cloth and Degreaser

The Most Important Step! Before you start routing the hose, please confirm that the Q-Connector's Pin Side (Male) and Socket Side (Female) are connected together as one complete hose unit.

# 7 Simple Steps to Install

## Step 1. Hose Routing

Route the entire hose unit through your bike frame.

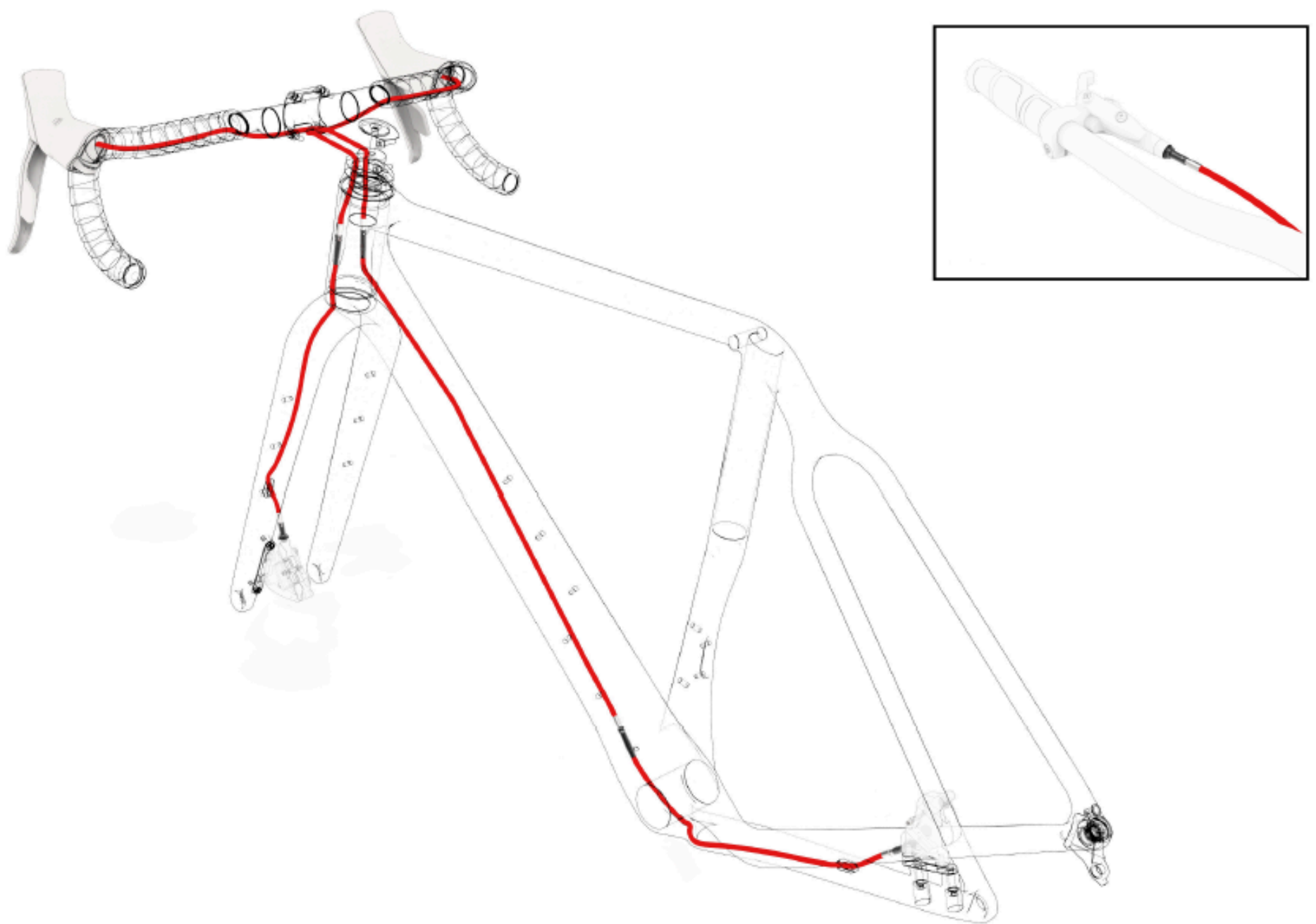

**CRITICAL TIP!** You **MUST** route the Pin Side (Male) towards your brake lever (handlebar). This is crucial for proper function.

## 7 Simple Steps to Install

### Step 2. Measure & Cut

1. Determine the final location where the Q-Connector will sit.  
(Ensure 4.5 cm of slack for cable movement)



2. At that exact point, use your hose cutter to cut the hose to the required length.



## 7 Simple Steps to Install

### Step 3. Connect to Lever

Connect and securely tighten the **Pin Side** hose end to your brake lever.

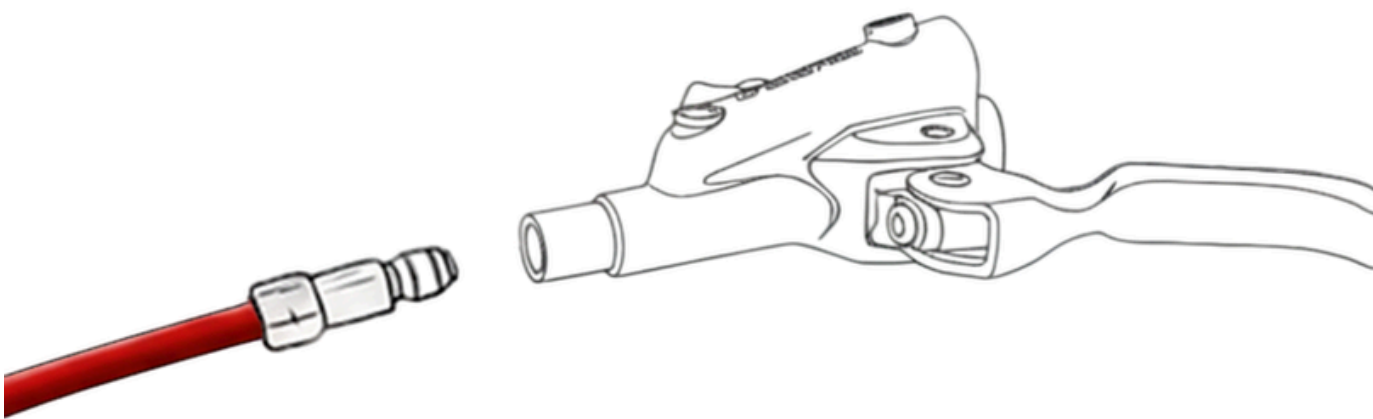

Mountain Bike

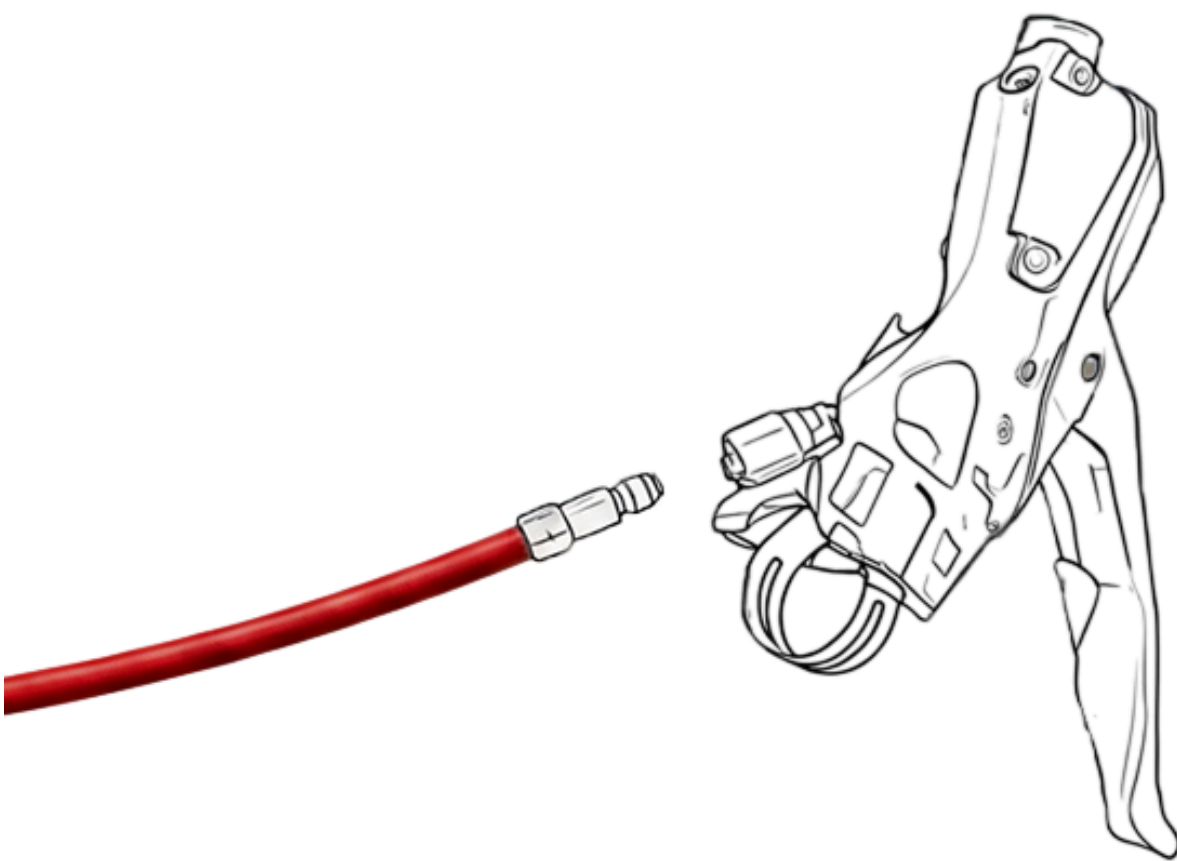

Road Bike

## 7 Simple Steps to Install

### Step 4. Connect to Caliper

Connect and securely tighten the Socket Side hose end to your brake caliper.

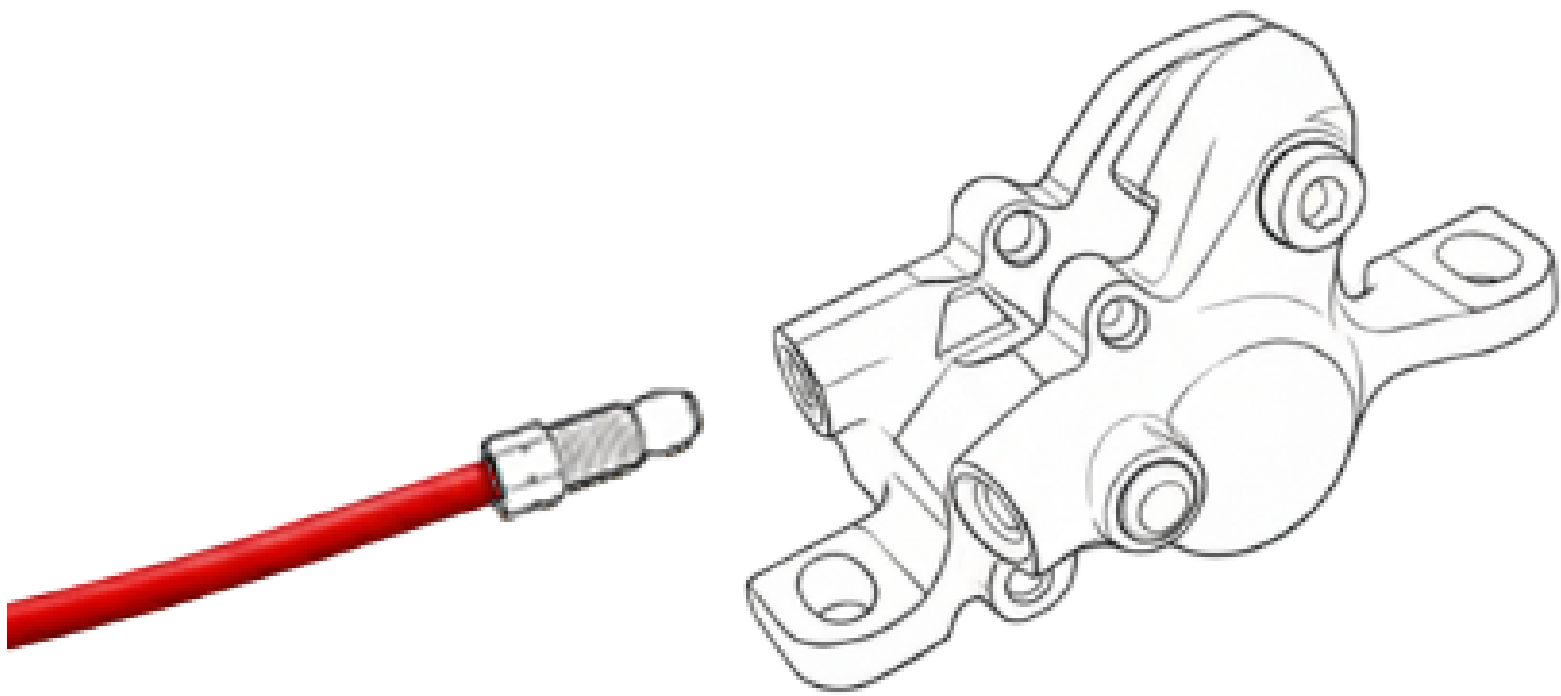

## 7 Simple Steps to Install

### Step 5. Connect the V2 Connector

Connect



Disconnect



## 7 Simple Steps to Install

### Step 6. Bleed Your Brakes

Follow your brake manufacturer's official service manual to perform a complete brake bleed. This removes any air introduced during the installation.



## 7 Simple Steps to Install

### Step 7. You're Done!

Your brake system is now fully installed and ready for the next step!

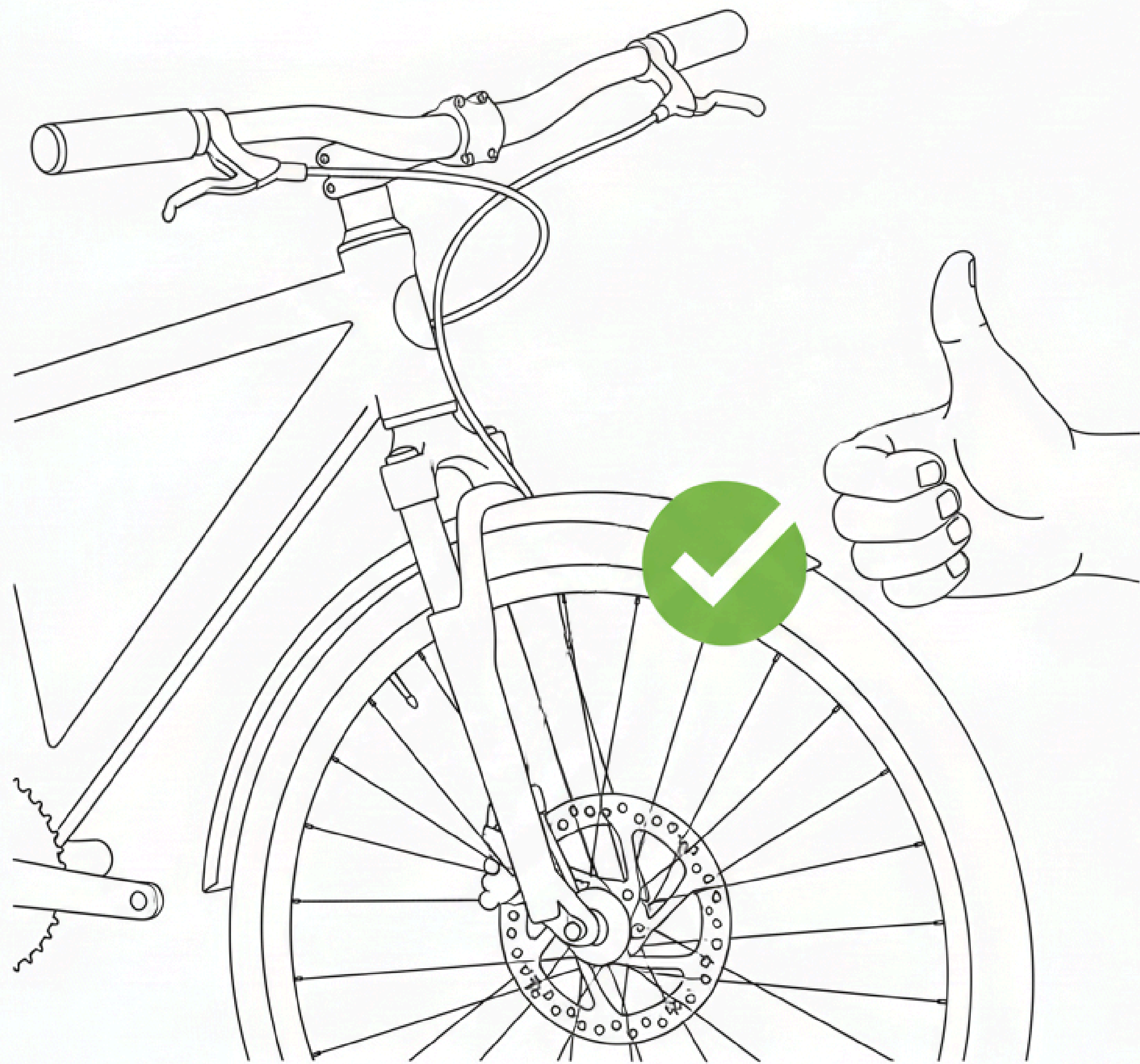

## Q-Connector Magic Features



### **NO LEAKS**

No Leaks on Disconnect: The built-in check valves ensure no fluid loss when you separate the connector.

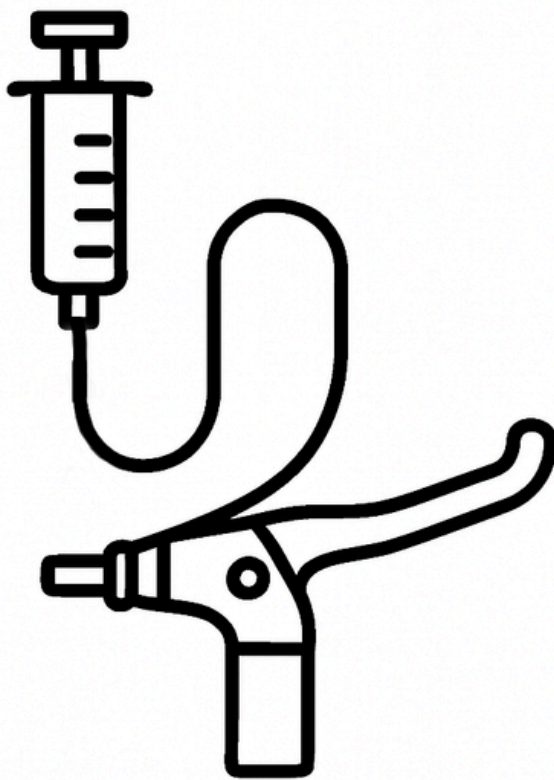

### **RE-BLEEDING FREE**

No Re-Bleeding Required: When you reconnect the Q-Connector, you can use your brakes immediately--no need to bleed the system again!



## Quick Maintenance Tips

**Keep it Clean:** Before every connection, wipe the connector area clean to ensure it is free of dust or grit, protecting the internal seal.

**Post-Installation Safety Check:** Connect and disconnect the Q-Connector at least 5 times. This action fully seats the internal seals, verify the brake lever feel is firm and solid.

**Pre-Ride Safety Check:** ALWAYS check that the brake lever feels firm and solid before every single ride. Never ride with a spongy brake lever.

**Check Torque:** After your first few rides, double-check that all threaded connections are still securely tightened.